

Drawings illustrate the structural insulated shell only, all internal and external finishes have been omitted.

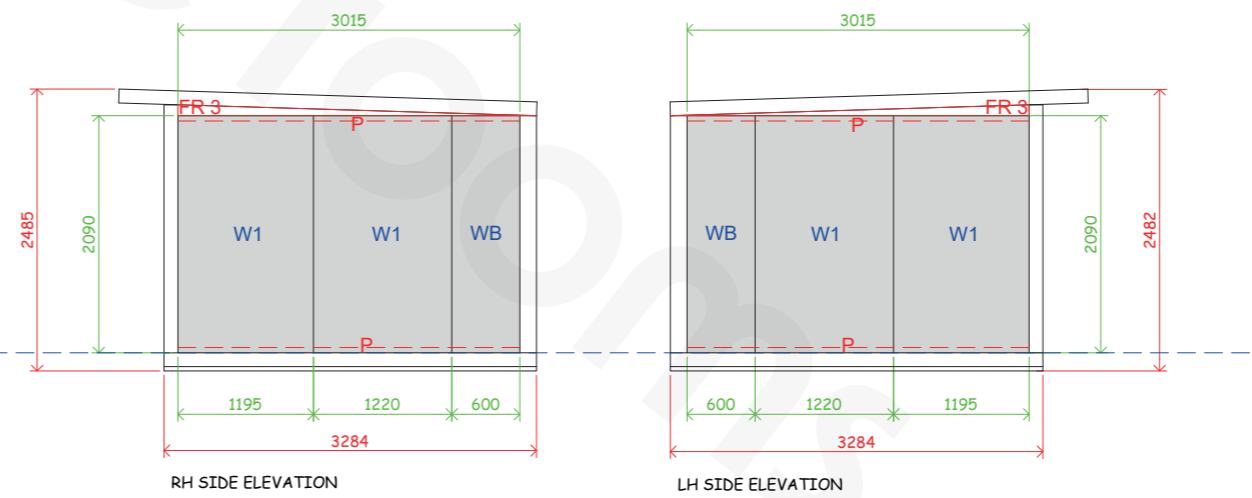

Drawings illustrate the structural insulated shell only, all internal and external finishes have been omitted.

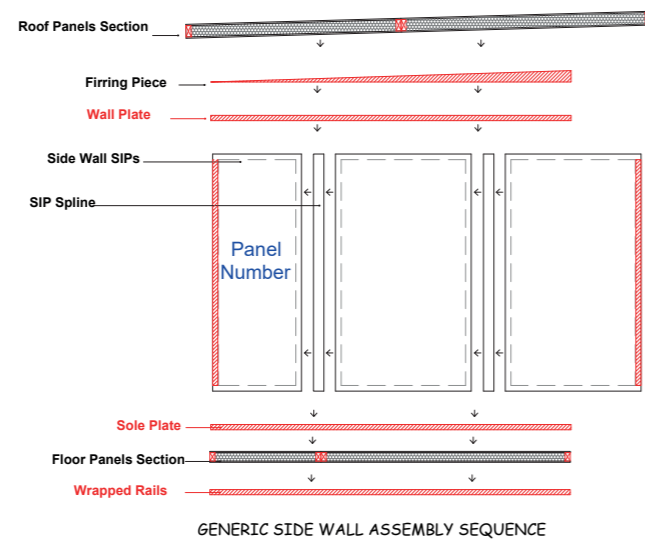
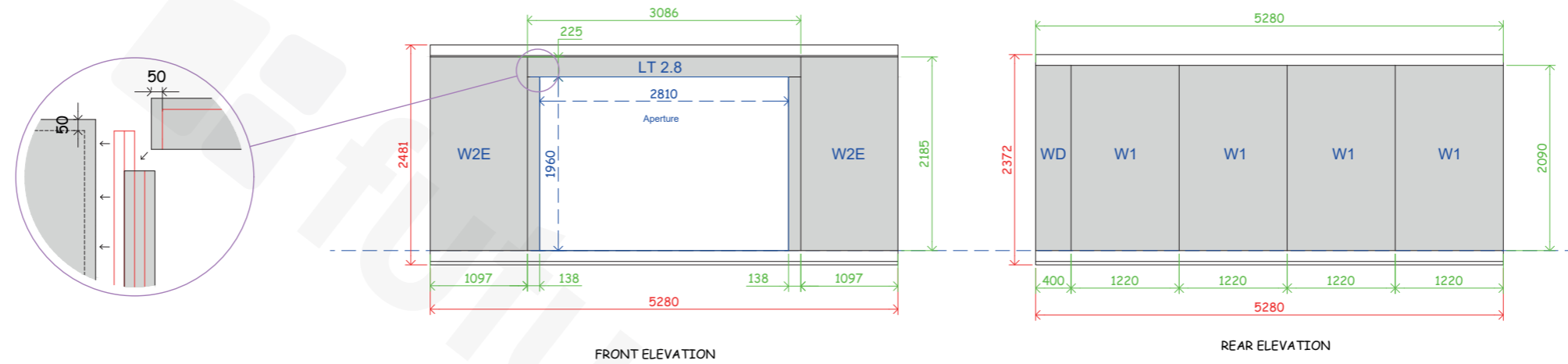
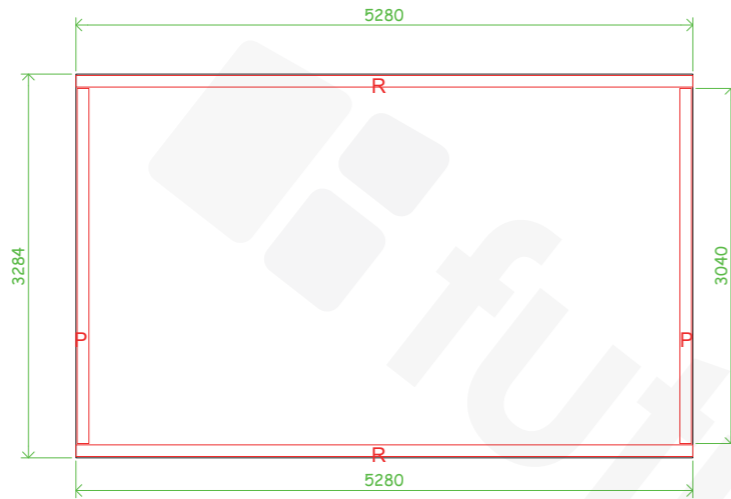

WALL PLATE PLAN

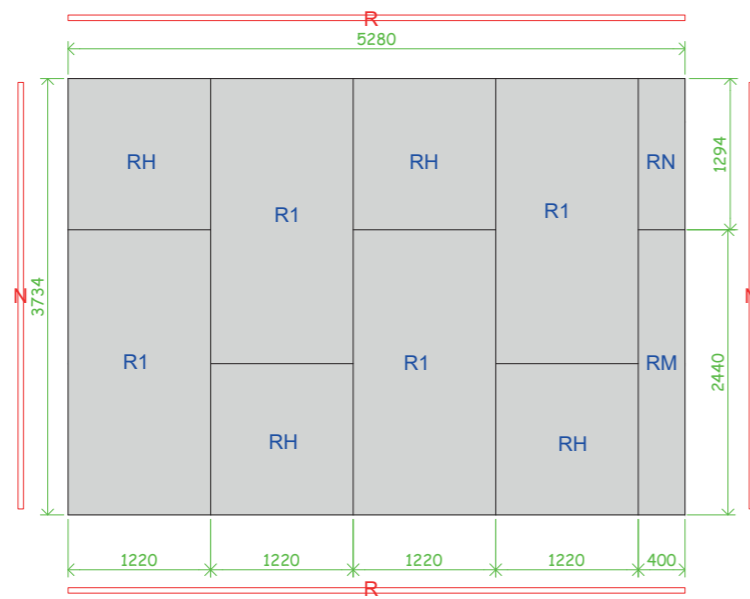

ROOF PANEL PLAN

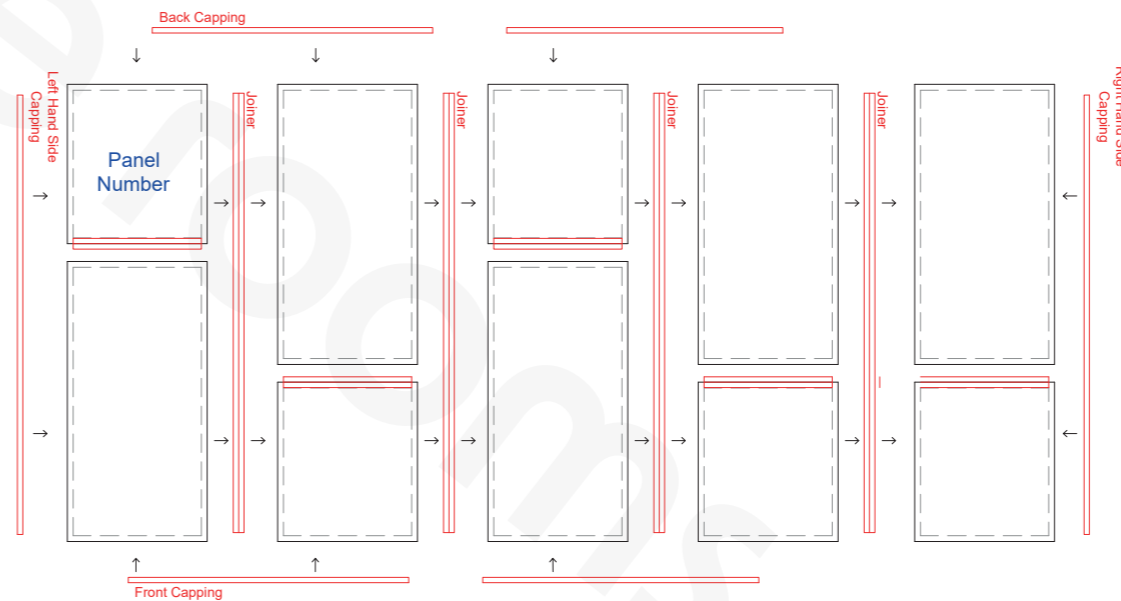

GENERIC FLOOR AND ROOF ASSEMBLY SEQUENCE  
 Note: number of panels will change depending on room dimension

Drawings illustrate the structural insulated shell only, all internal and external finishes have been omitted.